

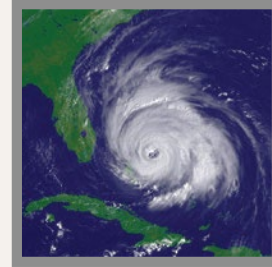

Welcome to Fleetwood Windows & Doors

Since 1961, Fleetwood has been the benchmark for modern windows and doors. Our line of impact rated products continues our vision to make narrow style, highly engineered products which accentuate your view and operate with ease. Each product in this brochure is designed, tested, and evaluated to be in compliance with the Florida Building Code (FBC) structural requirements including the "High Velocity Hurricane Zone" (HVHZ). Please note: most products have state non-impact ratings as well.



This brochure contains impact rated products only. Our comprehensive brochure is available online or by contacting the factory at 800-736-7363.

The "Little" Things

TRUE QUALITY COMES FROM A COLLECTION OF REFINED PARTS. Below are two examples of Fleetwood's commitment to build it better, not cheaper.



SLIDING DOOR ROLLERS: A2 & A3

- Made in the USA
- Certified Swiss precision bearings with European 440C stainless, using precision tuning, heat treatment, grinding and 'superfinishing'
- Hand assembled with 100% SPC (Statistical Process Control) and visually inspected
- Strict proprietary tolerances achievable by only the finest worldwide bearing manufacturers
- HRC 58 bearing hardness compared to HRC 40 industry standards (below 52 creates metallic particles acting as a grinding paste)
- Each bearing contains a special low friction contact seal with lifetime lubricant
- All rollers come with a Lifetime warranty



ARCHETYPE & ARCHETYPE NARROW LOCKING SYSTEM:

- Made in the USA
- Both systems earned a US Patent (Patent No. 8,186,189 B2)
- Constructed of #300 stainless steel
- Faceplates constructed of #300 stainless steel and electropolished
- Assembled with stainless steel fasteners
- Laminated 6 ply stainless steel hook
- Exposed handles cast with #316 stainless steel and electropolished
- Optional 5-pin keyed lock
- Dual latch on doors +96" height (Archetype only; 3070 & 3050)
- All latches come with a Lifetime warranty

Product Index

| GENERAL | | PAGE | |
|-------------------------------|-------------------------------|--------------------|-------|
| ALUMINUM FINISHES | | 2 | |
| DOORS | CONTENT | DOCUMENT # | PAGE |
| MULTI-SLIDE/POCKET | SERIES 3070-HI | FL-15560 | 3-4 |
| MULTI-SLIDE/POCKET | SERIES 3070-T "THERMAL FRAME" | FL-15560 | 5-6 |
| TRADITIONAL SLIDING | SERIES 3000-T "THERMAL FRAME" | FL-15560 | 7-8 |
| HINGED DOOR | SERIES 3900-T "THERMAL FRAME" | FL-17954 | 9-10 |
| WINDOWS | CONTENT | DOCUMENT # | PAGE |
| WINDOW-WALL FIXED SYSTEM | SERIES 3800-T "THERMAL FRAME" | FL-16925 | 11-12 |
| WINDOW-WALL W/OPERABLE INSERT | SERIES 3800-T W/SERIES 250-T | FL-14904, FL-14907 | 13-14 |
| CASEMENT & AWNING | SERIES 250-T "THERMAL FRAME" | FL-14904, FL-14907 | 15-16 |
| PRODUCT OPTIONS | | PAGE | |
| DOOR HARDWARE | | 17 | |
| WINDOW HARDWARE | | 18 | |

Aluminum Finishes

ONE OF THE UNIQUE TRAITS OF ALUMINUM IS ITS ABILITY TO HAVE MULTIPLE FINISHES. IF PROPERLY MAINTAINED, THESE FINISHES WILL LAST A LIFETIME. WE OFFER MORE INFORMATION ON OUR WEBSITE IN "MAKING THE RIGHT CHOICES" (DESIGNERS AND HOMEOWNERS SECTIONS).

ANODIZED

Anodizing is a chemical process that makes the aluminum surface harder and thicker. It was used by the US Military in WWII as a finish to protect against corrosion on its aircraft. [Process: Each extrusion is electrically charged while submerged in acid (changes aluminum oxide to aluminum hydrate). If an earth tone color is desired, the aluminum is dipped in a color tank and then sealed.]

STOCK FINISHES

Fleetwood offers its aluminum products in thousands of colors but offers the following two finishes with a faster production time.

CUSTOM COLOR ANODIZING

We offer two custom anodized colors, shown here. Customers should expect shade variation so if exact color uniformity is desired, paint may be the better choice.

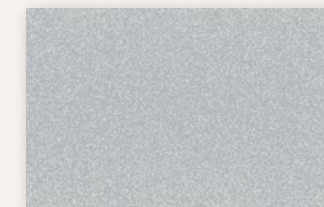

Class I Clear Anodize

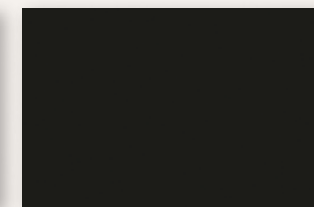

Class I Dark Bronze Anodize

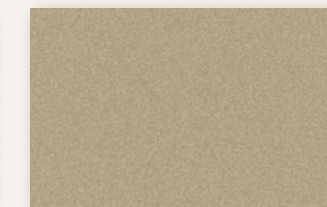

Class I Light Bronze (F1)



Class I Medium Bronze (F3)

PAINTED

We use the same paint (Kynar 500™) which high-rise buildings around the world demand because of its exceptional color retention and salt air protection. [Process: Each extrusion is chemically pretreated, painted electro-statically, then cured in an oven.]

12 OF OUR MOST POPULAR COLORS

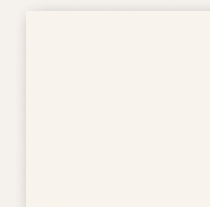

White #10

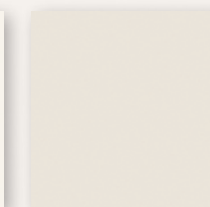

Bone White

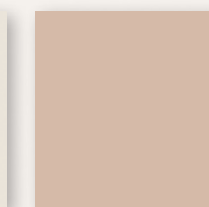

Beige

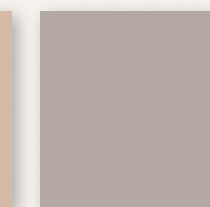

Light Seawolf

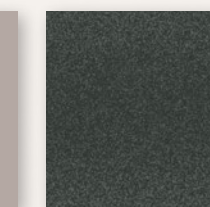

Medium Bronze

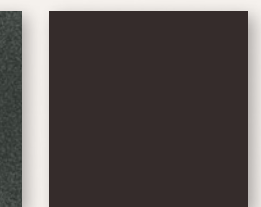

Statuary Bronze

Kynar 500® (Kynar 70% Standard 2-Coat)

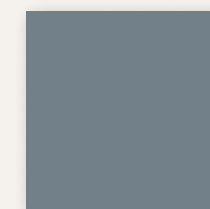

Fashion Gray

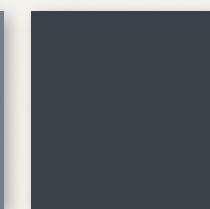

Charcoal Gray

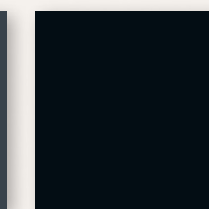

Black #10

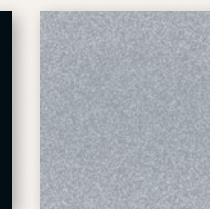

Silver
Mica 2-Coat



Brite Copper
Metallic 4-Coat

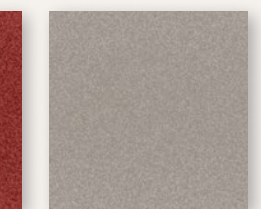

Champagne Sunstorm
Mica 2-Coat

Kynar 500® (Kynar 70% Standard 2-Coat)

Kynar 500® Specialty Coatings (Kynar 70%)

Please note: The colors in this brochure may vary from the anodized or painted aluminum extrusions.





| | | | |
|--|--|------------------------|-------------------------|
| TYPICAL CONFIGURATIONS | DESIGN PRESSURE | MAX PANEL WIDTH | MAX FRAME HEIGHT |
| <ul style="list-style-type: none"> Multi-Slide, Pocket and Corner (60°–135°) applications. Any combination of O & X panels—no limit on the number of panels. | +50.0/–55.0 PSF* thru +65.0/–75.0 PSF* | 62"* | 144"* |

ELEVATION VIEW:
PXXX CONFIGURATION
(shown with Archetype)

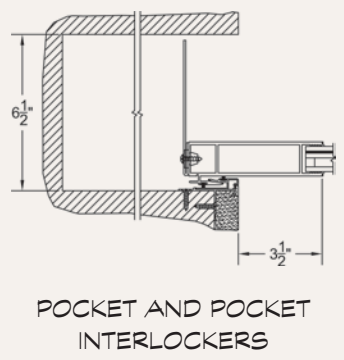
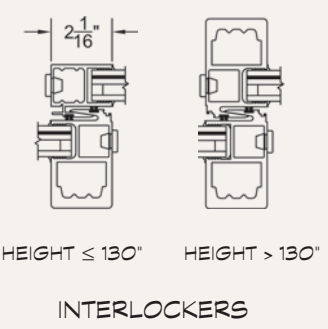
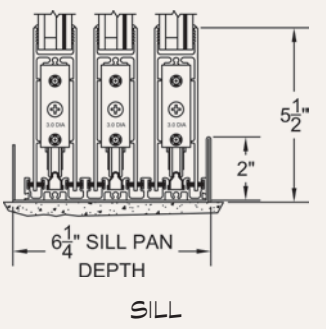
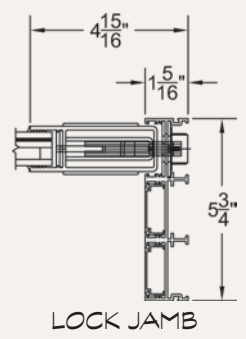
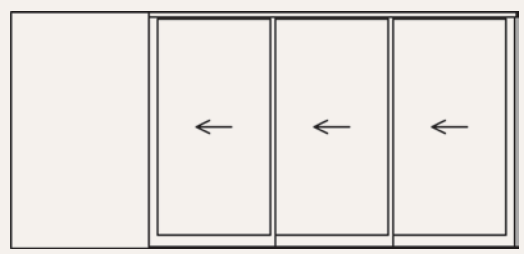
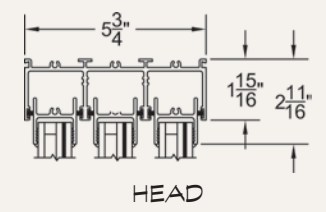

*Varies based on configuration and size.

DESIGN NOTES

- Huge sizes/thin sightlines.
- Easiest rolling door made.
- Weather rated.

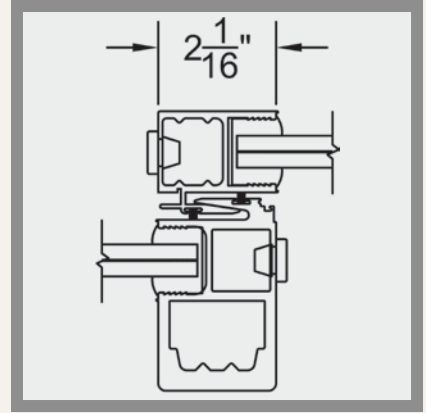

Narrow Interlockers:

Most impact rated sliding door products have a large vertical sightline at the interlockers. This of course is a negative aspect, especially if the homeowner has a beautiful view. Even though the 3070-HI performs mightily, it boasts a slender 2-1/8" dimension.

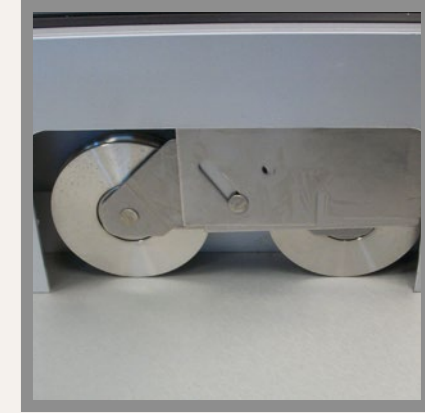

Rollers & Fillers:

Our Archetype roller uses an authentic precision bearing from Switzerland. Each bearing is carefully inserted into its 3" diameter stainless steel wheel, using American labor and strict quality control. These rollers provide for an operating force of only 1–3 lbs on panels weighing up to 350 lbs.

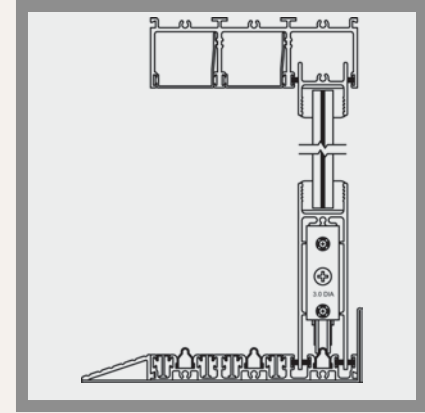

The Series 3070 comes standard with matching extrusions that fill unused cavities in the head, jamb and sill. These closers enhance the cosmetic beauty of the product but also serve the practical function of repelling sand, water, air and bugs.



Archetype:

The Series 3070-HI offers two lock stile choices: the Archetype (above left) and the Archetype Narrow (above right). This patented latching system is cast with 316 stainless steel and fits snug against the extrusion to prevent damage to other panels during operation. The stainless steel is electro-polished for the best marine grade protection possible. The actuator is easy to operate and expels a large, laminated hook latch similar to commercial products.

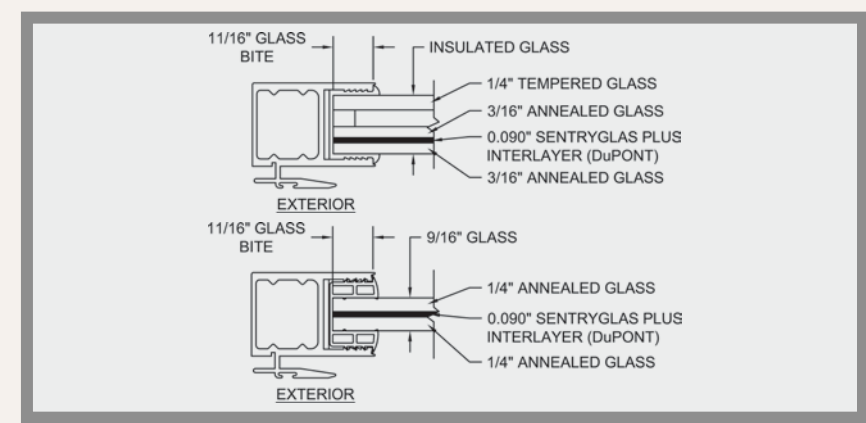

Glazing Type:

The Series 3070-HI was tested and certified using two primary glass types: a 9/16" monolithic laminated glass and an insulated laminated glass. Both glass types utilize a DuPont™ SentryGlas® Plus innerlayer and are dry glazed.



Photo by Maria Merano © 2016

| | | | |
|---|--|--|--|
| <p>TYPICAL CONFIGURATIONS</p> <ul style="list-style-type: none"> Multi-Slide, Pocket and Corner (90°–135°) applications. Any combination of O & X panels—no limit on the number of panels. | <p>DESIGN PRESSURE</p> <p>+50.0/–55.0 PSF</p> | <p>MAX PANEL WIDTH</p> <p>62"</p> | <p>MAX FRAME HEIGHT</p> <p>120"</p> |
|---|--|--|--|

ELEVATION VIEW:
PXXX CONFIGURATION
(shown with Archetype Narrow)

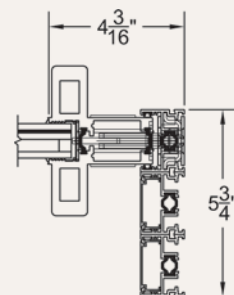
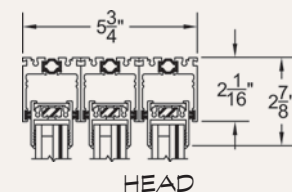

(shown with Archetype Narrow)

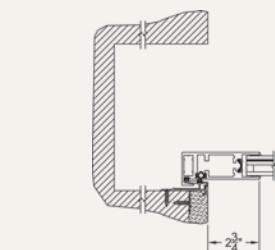
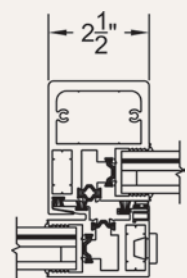
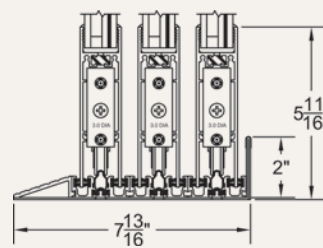

(shown with Archetype Narrow)



DESIGN NOTES

- Slender interlockers (2-1/2").
- Interior/exterior blended floor option (Sub Sillpan)

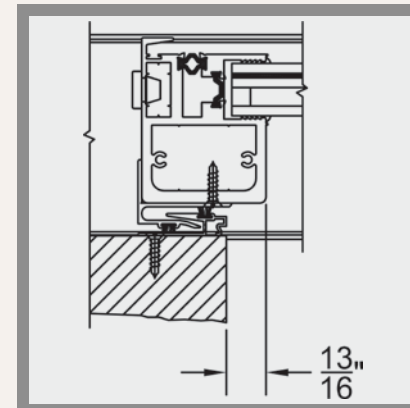

Reverse HP Interlocker:

Pocketing doors exceeding 130" in height require the HP2 interlockers (pictured above). This feature allows all such panels to bury inside the pocket.

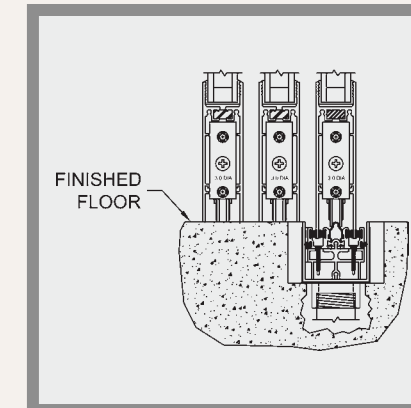

Sub Sillpan Option:

This feature creates a continuous floor look with the added benefit of weather performance. Specifically, the staggered track option achieves a 6 PSF water test result, which is equal to an HC 40 (Heavy Commercial) door. The detail above shows how the tracking system can be level with the finished floor but still provide exceptional water performance underneath. This feature is also available on the Series 3070-HI (pages 3–4).

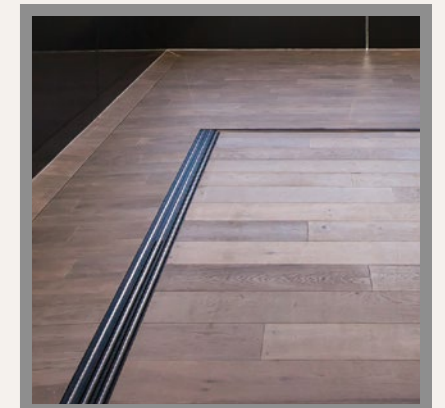

Minimalistic Hardware:

The standard locking system is our patented Archetype system (page 1). However, the 3070-HI, 3070-T, and 3000-T also offer the option of a sleeker locking stile (pictured above) called the Archetype Narrow. The Narrow includes the same latch as the Archetype but with a vertical actuation and a smaller footprint.

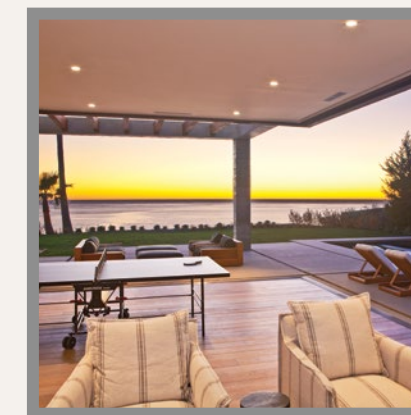

No Post Corner:

A custom extrusion was created to allow 90° and odd angle corners without the need for a post or jamb. The result is the strongest and most attractive corner door on the market. Imagine the stunning view once the doors are in the fully opened position. To make it even more dramatic, design the walls to allow these door panels to disappear into a pocket.





| | | | |
|--|------------------------|------------------------|-------------------------|
| TYPICAL CONFIGURATIONS | DESIGN PRESSURE | MAX PANEL WIDTH | MAX FRAME HEIGHT |
| • Two, three and four panels (i.e. XO,OXO, OXIXO). | ±50.0 PSF* | 62" | 120" |

ELEVATION VIEW:
OXIXO CONFIGURATION
(shown with Archetype Narrow)

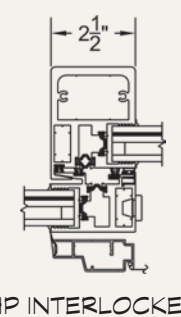
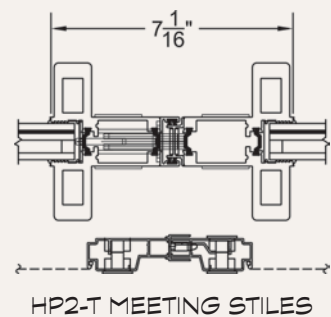
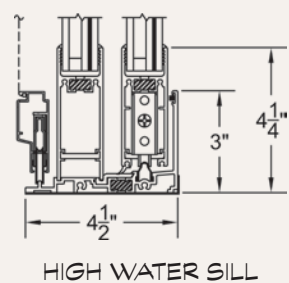
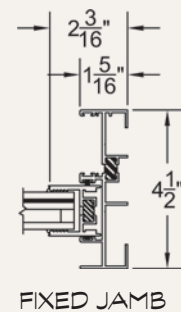
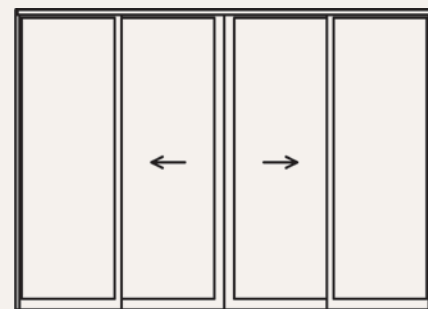
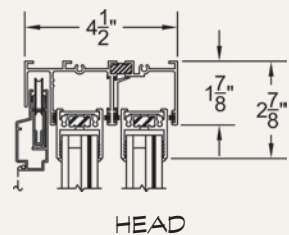

*Varies based on configuration/selected options.



DESIGN NOTES

- Easiest rolling patio door on the market.
- Slim interlocker sightline.



Swiss Bearing Rollers:

Similar to the Archetype roller used in the Series 3070-HI, the roller used in the Series 3000-T is made in the USA and comes with authentic Swiss bearings.

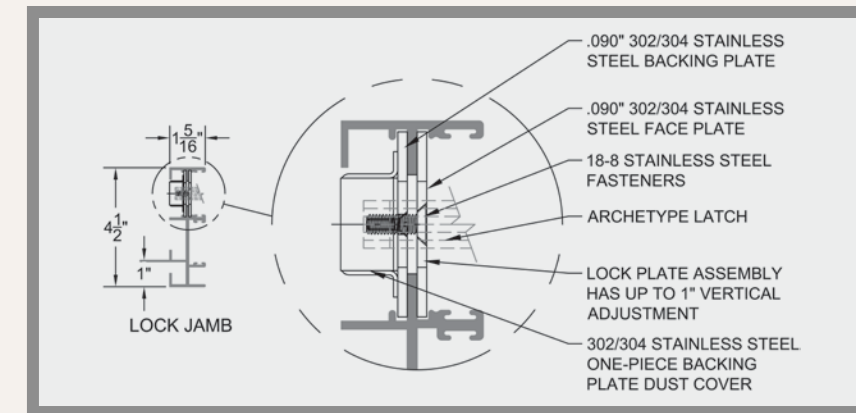

Stainless Steel Components:

The Series 3000-T is ideal for coastal applications because its standard hardware is stainless steel. The locking system, strike plate and even the assembly screws are high grade stainless steel. (Strike plate illustrated above.)



Archetype Narrow:

The Series 3000-T offers two stile choices: the Archetype (see page 4) or the slimmer Archetype Narrow (above). The Narrow includes the same latch as the Archetype but with a vertical actuation and a smaller footprint.

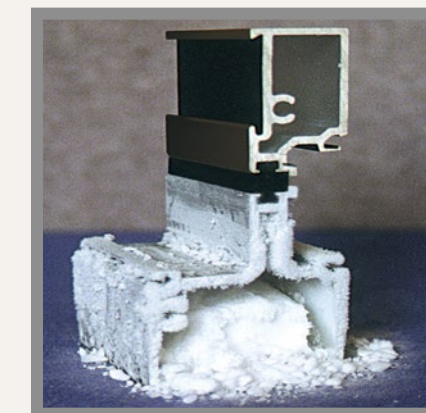

"Thermal Frame" Extrusions:

The ultimate combination of structural integrity and energy efficiency. Each extrusion was engineered to provide the precise location of the polyurethane so performance was achieved and aesthetics were not compromised. When the Series 3000-T is closed, you cannot tell the extrusions are insulated. Cheaper products have made no attempt to hide the black lines.



| TYPICAL CONFIGURATIONS | DESIGN PRESSURE | MAXIMUM SIZES |
|--|---|--|
| <ul style="list-style-type: none"> Hinged, sidelite and transom applications In swing and out swing. | <p>±50.0 / -50.0 PSF* thru ±65.0 / -65.0 PSF*</p> | <ul style="list-style-type: none"> Hinged with Transom: 108" frame width x 168" frame height Single Hinged Panel: 48" frame width x 120" frame height Pair Hinged Panels: 80" frame width x 120" frame height Sidelite: 45" width x 96" height |

ELEVATION VIEW:
O/HH

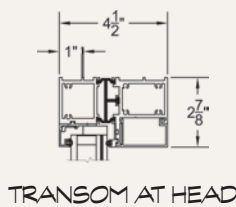

TRANSOM AT HEAD

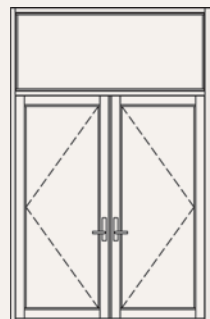

ELEVATION VIEW:
OHHO

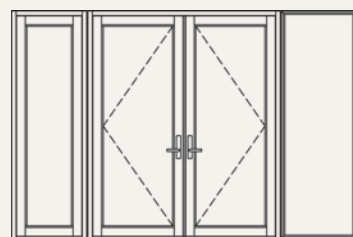

WIDE STYLE
FIXED LITE 3800-T MULLION
FIXED LITE

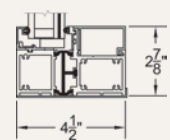

NARROW
FIXED AT SILL

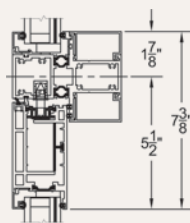

TRANSOM

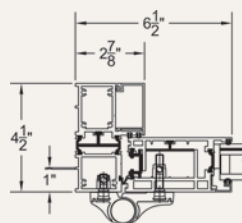

HINGE AT JAMB

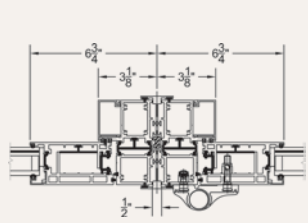

WIDE FIXED AT TDL /
HINGE AT TDL

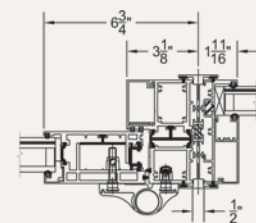

3900-T HINGE JAMB /
3800-T FIXED JAMB

*Varies based on configuration.



DESIGN NOTES

- Fills openings as large as 12' tall.
- Modern design hinges and hardware.

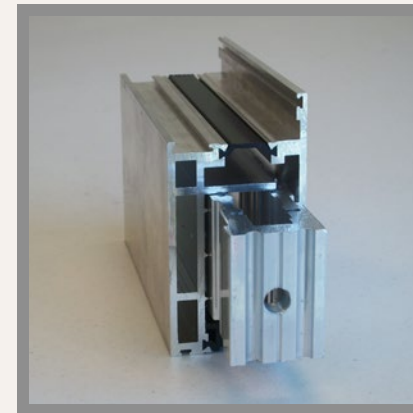

Corner Strength:

One of the design enhancements of the Series 3900-T is butt joinery instead of mitering, because it offers a look more consistent with modern architecture. In order to achieve this feature, we needed an exceptional corner key. From the image above, you can begin to appreciate the strength of each corner as you consider the mass of the key. The wall thickness exceeds 5/16" in most locations and penetrates 4-1/4".

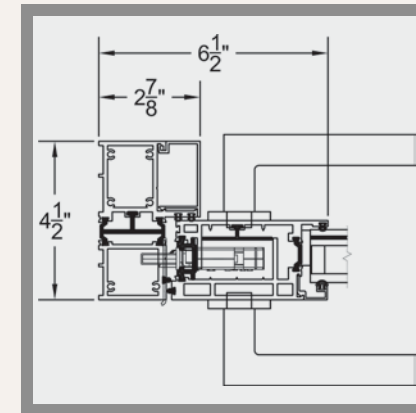

Sleeker Sightline:

Take note of the "boxy" theme for all extrusions in the Series 3900-T. Each perimeter frame and vent was designed with the purposeful intention of creating a hinged door that has the engineering fortitude to accommodate larger openings, e.g. 96" x 120", yet retain clean, hard lines with a flush face.



Hinges:

The Savio hinges on the Series 3900-T can hold as much as 360 lbs. of hang weight. Additionally, these same hinges have three points of adjustment to compensate for natural settling of the building. Another feature is the ease of panel removal from the main frame, which allows the glass panel to be removed until construction is completed.

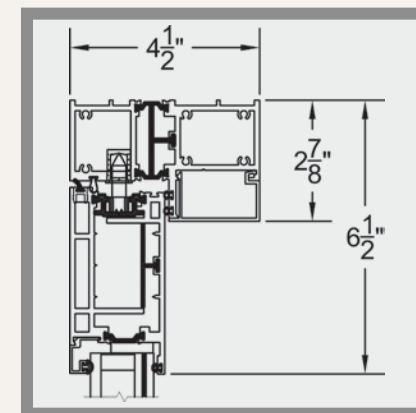

"Thermal Frame" Technology:

The Series 3900-T thermal barrier is a modern technology called "Strut." This contemporary process joins two extrusions together with a high resin "strut" instead of pouring and debridging a single extrusion. We selected this newer technology because it offers greater extrusion design flexibility without compromising thermal performance.





| TYPICAL CONFIGURATIONS | DESIGN PRESSURE | MAXIMUM SIZES |
|---|--|---|
| <ul style="list-style-type: none"> • 000-GTF, 0/0/0-GTF, 00-GTF, 00/00-GTF | ±50.0 / -50.0 PSF* thru ±65.0 / -65.0 PSF* | <ul style="list-style-type: none"> • Unlimited Inline: 42" max centerline x 96" frame height • Stacked: 42" x 180" frame or 96" x 120" frame • Single Fixed: 60" x 120" frame or 50" x 144" frame • Double or Intersecting: 120" frame width x 120" frame height • Unlimited jamb muller frames: 60" x 120" panels |

ELEVATION VIEW:
000-GTF
CONFIGURATION

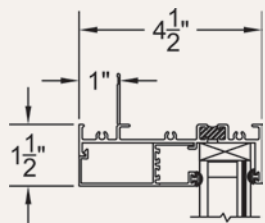

HEAD

ELEVATION VIEW:
0/0/0-GTF
CONFIGURATION

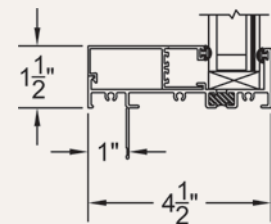
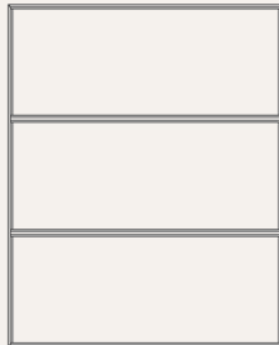

SILL

ELEVATION VIEW:
00/00-GTF
CONFIGURATION

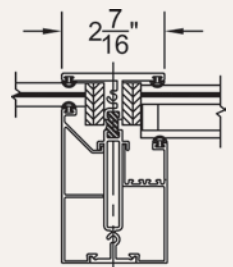
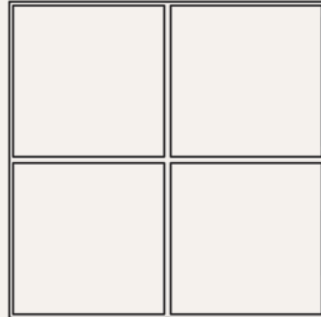

HORIZONTAL/ VERTICAL TDL

*Varies based on configuration.

DESIGN NOTES

- Sleek sightlines.
- Design layout freedom.



Storefront Design:

Designers want the hard lines seen in typical storefront but shudder at the thought of using commercial products for a variety of reasons. Our Series 3800-T fixed window system is the answer. It has similar designs as storefront but NONE of the downfalls, such as field drilled weep holes.

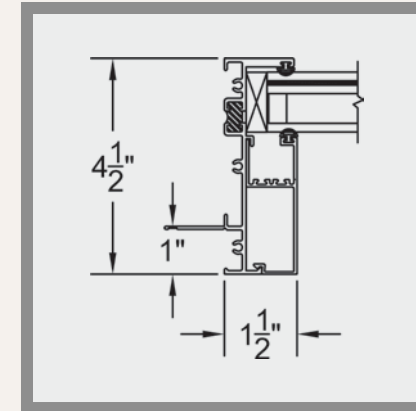

Sleek Sightlines:

The jamb-glass dimension of the Series 3800-T is a slender 1-7/16".

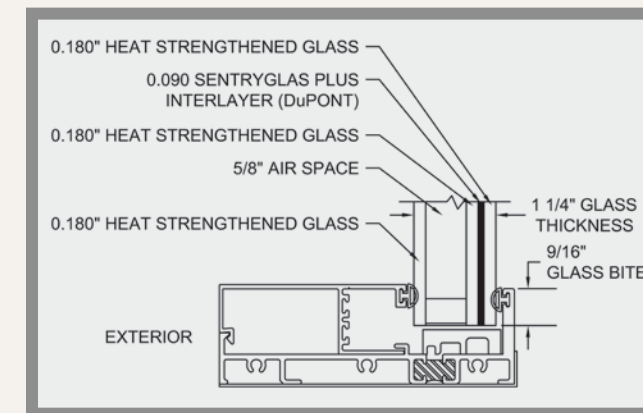

Glazing Type:

The Series 3800-T was tested and certified using a 1.25" overall insulating laminated glass that includes a DuPont™ SentryGlas® Plus innerlayer.

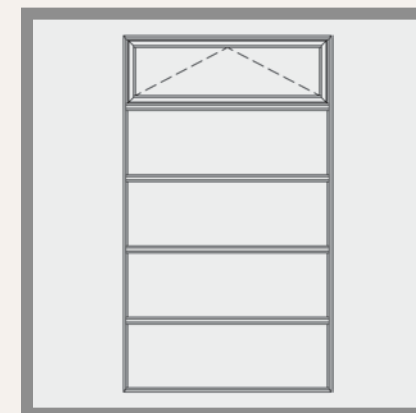

Window Insert Option:

Series 250-T casements and awnings can be inserted into the Series 3800-T system **in lieu of glass**. The elevation above provides an example configuration. Please see pages 13–14 for additional information and architectural details.

SERIES 3800-T W/SERIES 250-T INSERTS

IMPACT RATED "THERMAL FRAME" FIXED WINDOW

W/ CASEMENT/AWNING INSERTS

FL-14904, FL-14907



Photo by Laura Petrilla

| | | |
|--|---|---|
| <p>TYPICAL CONFIGURATIONS</p> <ul style="list-style-type: none"> • Awning, casement, and fixed | <p>DESIGN PRESSURE</p> <p>±65.0 PSF</p> | <p>MAXIMUM SIZES</p> <ul style="list-style-type: none"> • Unlimited frame width, max frame height: 84" • Stacked: 42" x 180" frame |
|--|---|---|

**ELEVATION VIEW:
O/O/O-GTF w/Awning and Casement Inserts**

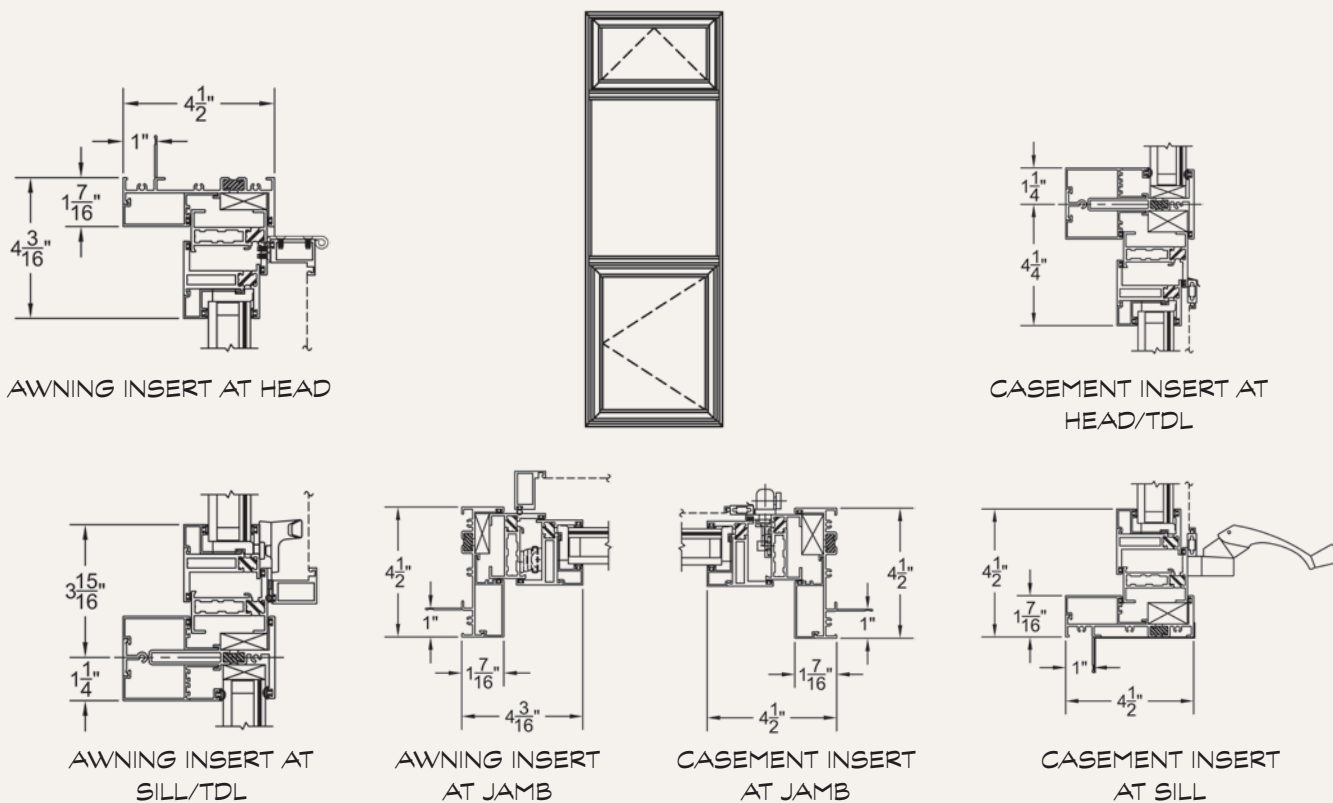

DESIGN NOTES

- Operable window inserts maximize view.
- Insert negates the need for exposed sealant.

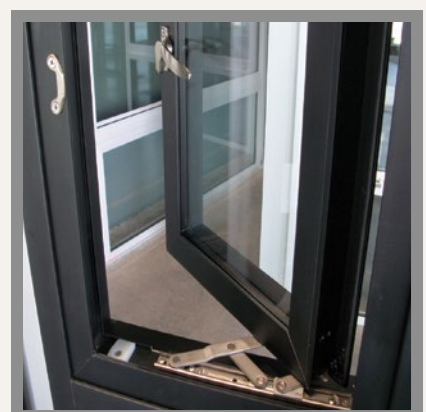

Stainless Steel Hardware:

The standard operating hardware is a dual arm stainless steel device. For larger or heavier vents, we provide stainless steel butt hinges and a single, stainless steel operator arm.



Concealed Hinges:

The 4-bar hinges offer the cleanest possible look by concealing the hinges inside the framing.

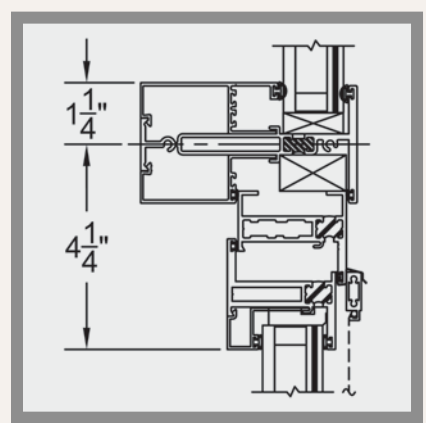

More Glass:

Typical industry window inserts take up available glass area and require unsightly caulking around the perimeter. Fleetwood inserts are enveloped by the main frame.



Removable Hinged Screen:

When cam handles and 4-bar hinges are selected, awning and casement windows come with a robust hinged screen that is removable for cleaning.

SERIES 3800-T/250-T



CONFIGURATIONS & MAX SIZES

CASEMENT:
40.25" X 63.25" (4-Bar Hinges)
39.75" x 81.75" (S.S. Butt Hinges)

AWNING:
40.25" x 82.25" (4-Bar Hinges)
63.25" x 40.25" (4-Bar Hinges)

DESIGN PRESSURE

±65.0 PSF

ELEVATION VIEW: C

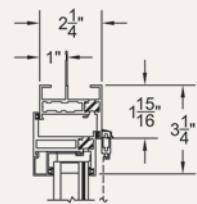
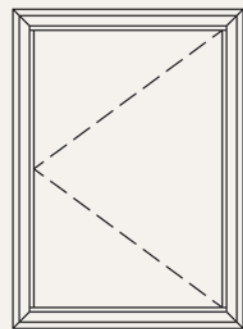

HEAD

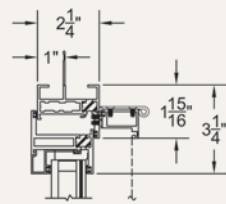

HEAD

ELEVATION VIEW: A

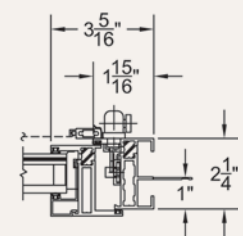
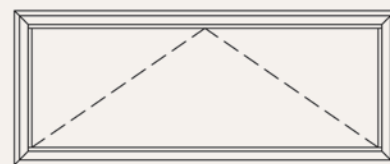

LOCK JAMB

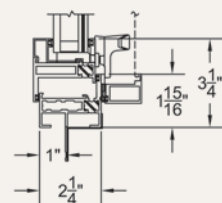

SILL

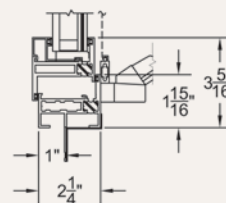

SILL

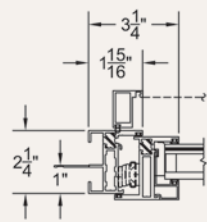

JAMB



DESIGN NOTES

- Stainless steel butt hinges.
- Sleek sightlines with huge vent sizes.

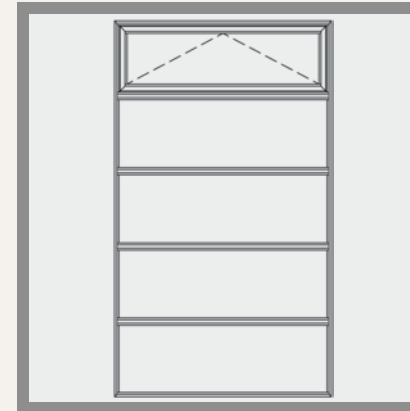

Window Insert Option:

Series 250-T casements and awnings can be inserted into the Series 3800-T system in lieu of glass. The elevation above provides an example configuration. Please see pages 13–14 for additional information and architectural details.



Stainless Steel Butt Hinges:

Each vent comes with four narrow footprint hinges. The hinges are #304 stainless steel and are finished with either black paint or a natural electropolish.

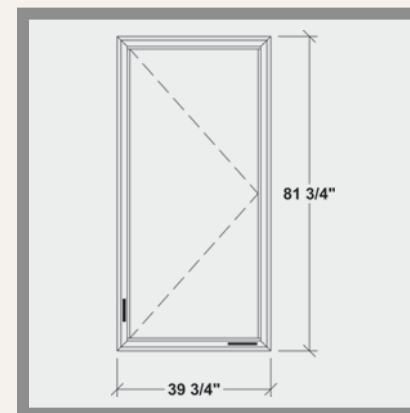

Huge Casement Vents:

The Series 250-T was designed to perfectly balance strength and beauty.

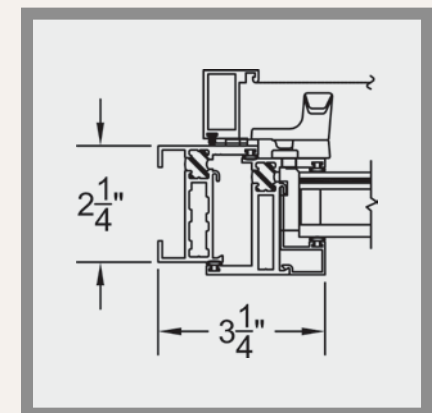

Hinged Screen:

This austere new option features a magnetic keeper & latch, and neoprene bulb as the bug guard. Hinges are mounted top and bottom for casements and left-top and right-top for awnings. This feature is only offered with the 4-bar hinge option, which is what the factory recommends for coastal and high wind projects.



Door Hardware

Most hardware shown is standard finish brushed stainless steel. Some hardware is available in a black powder coat finish. For more detailed information, navigate to the appropriate product page and select the Hardware link in the Optional Features section online.

ARCHETYPE & ARCHETYPE NARROW

POCKET/MULTI-SLIDER: SERIES 3070-HI, 3070-T
SLIDING DOOR: SERIES 3000-T

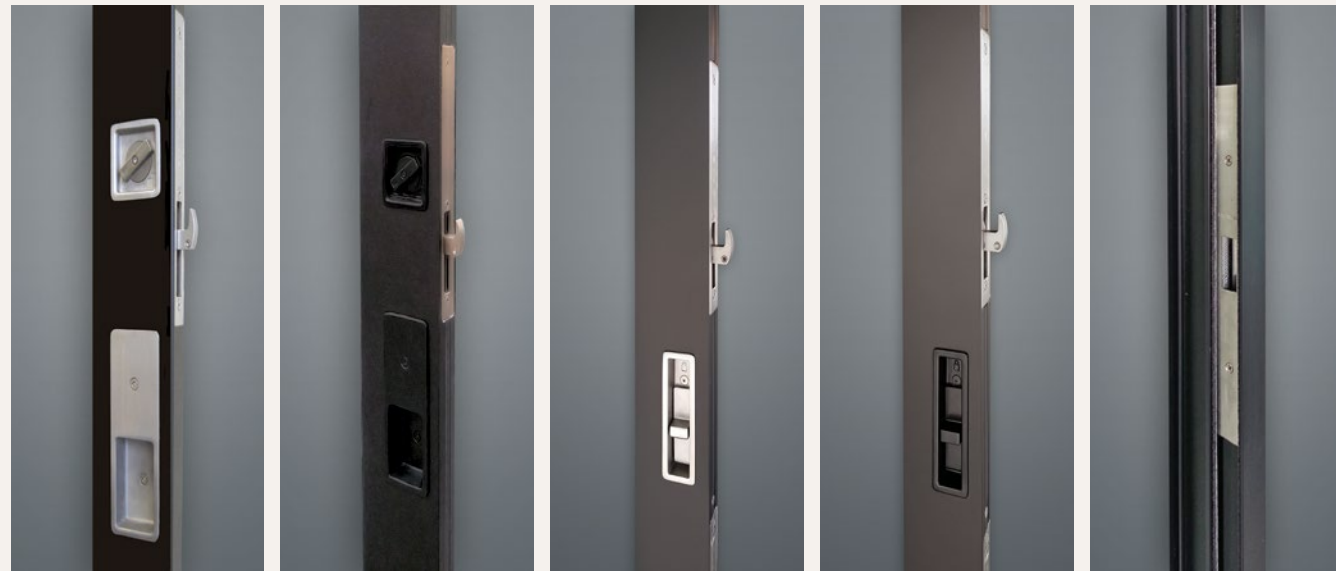

Stainless Archetype (Brushed) Stainless Archetype (Black Paint) Stainless Archetype Narrow (Brushed) Stainless Archetype Narrow (Black Paint) Stainless Strike Plate (Adjustable)
(Series 3070-HI, 3070-T & 3000-T) (Series 3070-HI, 3070-T & 3000-T) (Series 3070-HI, 3070-T & 3000-T) (Series 3070-HI, 3070-T & 3000-T) (Series 3070-HI, 3070-T & 3000-T)

ARCHETYPE ROLLERS & TRACK



A2 (Stainless Roller—2" diameter) Swiss Precision Bearings (Series 3000-T) A3 (Stainless Roller—3" diameter) Swiss Precision Bearings (Series 3070-HI & 3070-T) Stainless Track Insert (Shown in 2 track 3070-HI sill)

HINGED DOOR: SERIES 3900-T

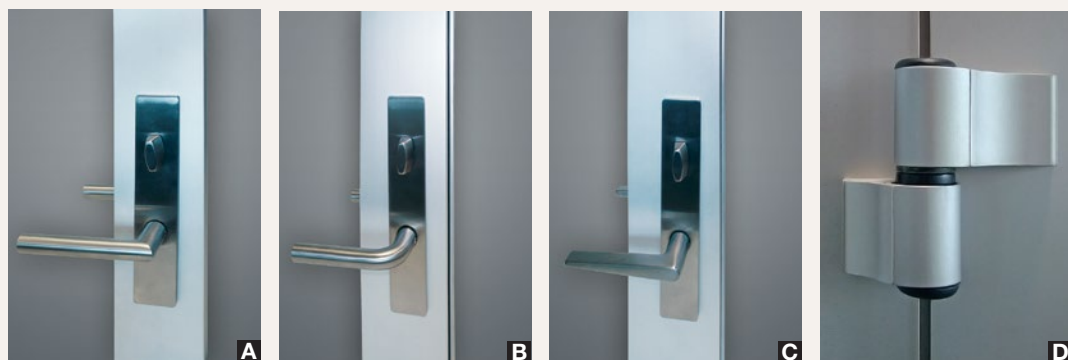

A. Stainless FSB Lever #1078 (Standard)
B. Stainless FSB Lever #1075
C. Stainless FSB Lever #1005
D. Savio Butt Hinges (Anodized Finish)

Window Hardware

Hardware shown is standard finish brushed nickel. Some hardware is available in black or gray painted finishes (requires less maintenance on the coast). For more detailed information, navigate to the appropriate product page and select the Hardware link in the Optional Features section online.

CASEMENT: SERIES 250-T

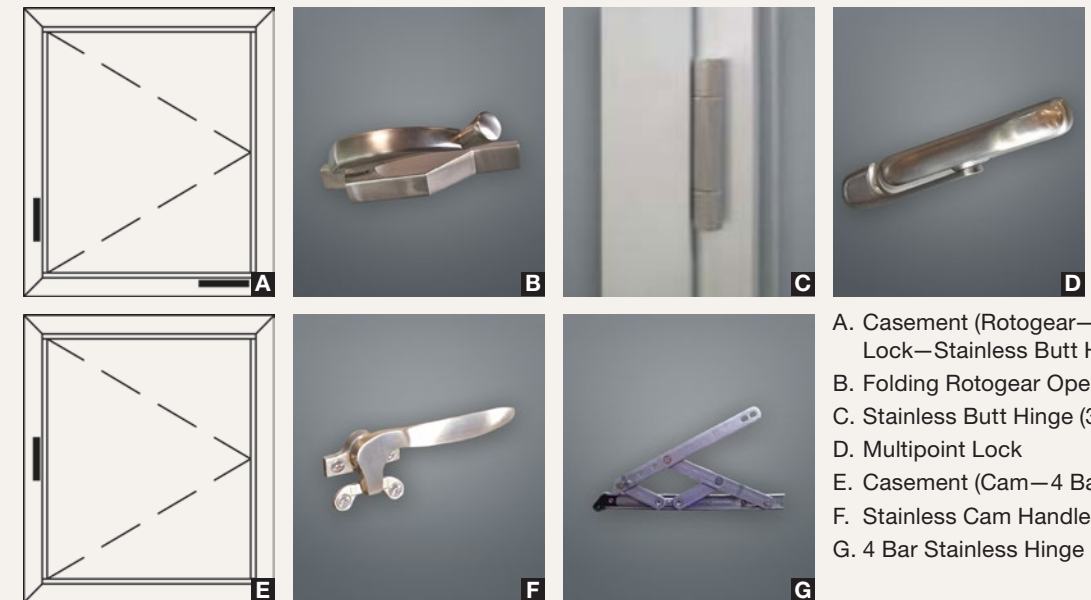

A. Casement (Rotogear—Multi-Point Lock—Stainless Butt Hinges)
B. Folding Rotogear Operator¹
C. Stainless Butt Hinge (3")
D. Multipoint Lock
E. Casement (Cam—4 Bar Stainless Hinges)
F. Stainless Cam Handle²
G. 4 Bar Stainless Hinge

AWNING: SERIES 250-T

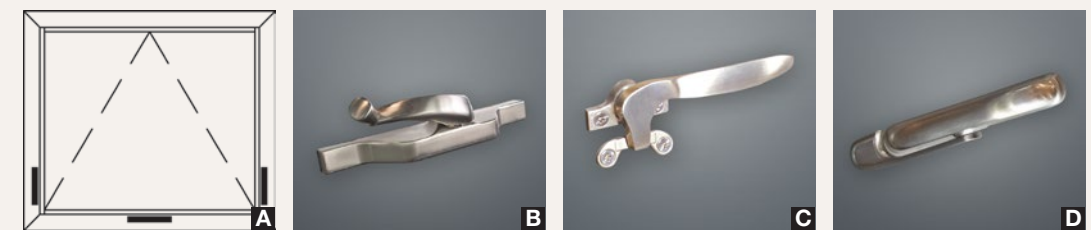

A. Awning (Rotogear—Security Locks—4 Bar Stainless Hinges)
B. Folding Rotogear Operator¹
C. Stainless Cam Handle
D. Multipoint Lock

SCREENS

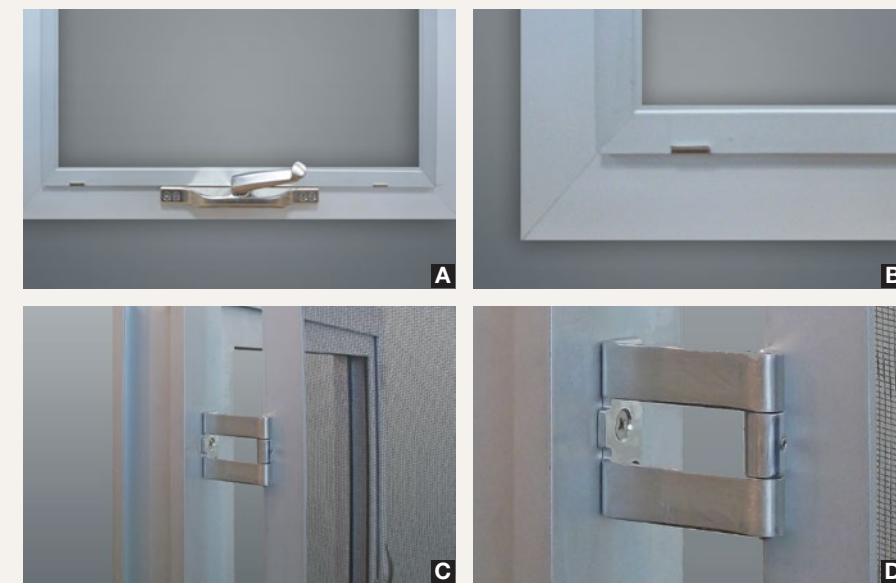

A. Flat Screen—Stainless Clip
B. Flat Screen—Stainless Clip (Close up)
C. Hinged Screen—Stainless Hinge
D. Hinged Screen—Stainless Hinge (Close up)

4 screen clips provided per screen.
By default, awning hinged screen hinges are located across the top of the vent and casement screen hinges are located on the side of the vent.

¹Not intended to be left open when wind speeds exceed 10 mph.
²Approved to be left open during wind speeds of up to 25 mph.

FLEETWOOD WINDOWS & DOORS FACTORY & SHOWROOM



WE INVITE YOU TO VISIT OUR 207,000 SQUARE FOOT FACTORY WHICH IS LOCATED IN SOUTHERN CALIFORNIA. OUR SHOWROOM IS EQUIPPED WITH A BROAD SAMPLING OF EVERY PRODUCT WE MANUFACTURE. CONTACT ONE OF OUR INSIDE SALES AGENTS TO SET UP AN APPOINTMENT.

Finding A Dealer:

We offer a convenient way to find a dealer. On our website, select “Dealer Search” and follow the drop down options to find a dealer near you.

Budget Pricing:

If your project is located outside our major markets, we offer an alternative method for a price quote. On our website, select the appropriate category of Homeowners or Designers and follow the drop down option for “Budget Pricing.” Our Inside Sales staff will process your quote within 72 hours.

More Information?

We encourage you to visit our website at www.FleetwoodUSA.com.

Important

The Limited Lifetime Warranty and the Care & Maintenance Instructions are available on our website.



Fleetwood Windows & Doors

1 Fleetwood Way, Corona, CA 92879
P.O. Box 1086, Corona, CA 92878-1086

800.736.7363
951.279.1070

www.FleetwoodUSA.com
Sales@FleetwoodUSA.com



Conformance to:
AAMA/WDMA/CSA 101/I.S.2

DISTRIBUTED BY:



*Authorized Dealers can buy glass to install in Fleetwood products. If you desire factory glazing and the subsequent glass warranty, make sure the dealer is providing factory glazed doors and windows.



All detail subject to change without notice. April, 2021.
Copyright © 2021 Fleetwood Windows & Doors. All rights reserved.